

## KLAXON ELECTROMAGNETIQUE

### Modèles G2 - G3 - G4 - G5

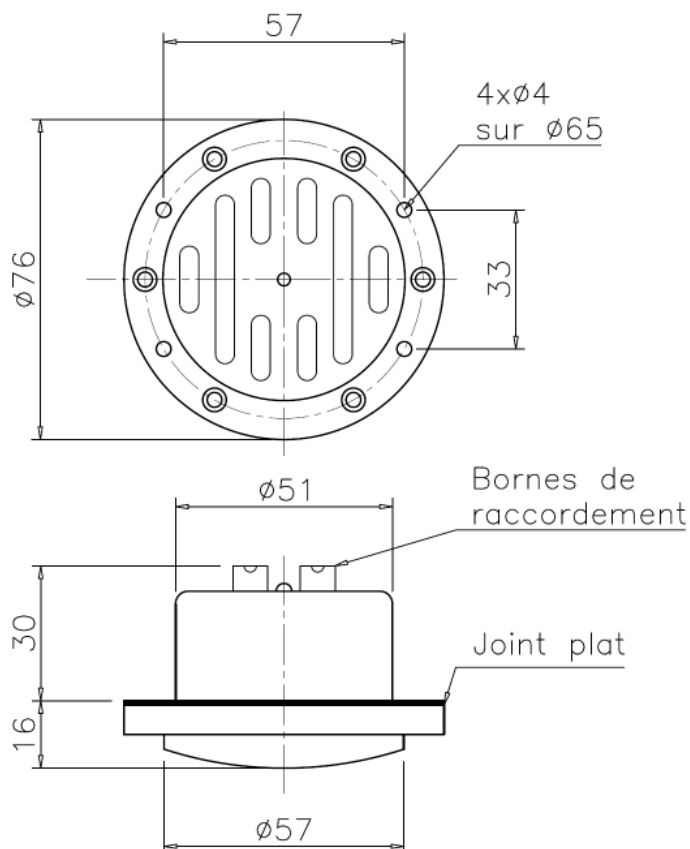
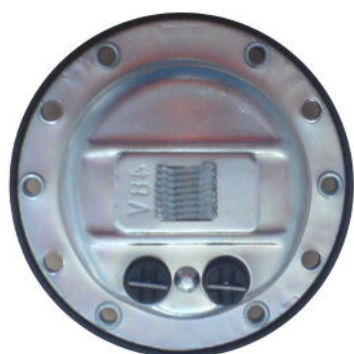

Carcasse métallique électrozinguée  
Peinture époxy noire sur façade visible  
Consommation courant : 0.28A (50Hz)  
Temps de travail en continu : 3min

	G2	G3	G4	G5
dB à 1m	90-95dBA			
Alimentation	24Vac	48Vac	110Vac	220Vac

#### Option :

Support plastique pour fixation en saillie  
Hauteur : 56mm



## KLAXON ELECTROMAGNETIQUE

### Modèles B2 - B3 - B4

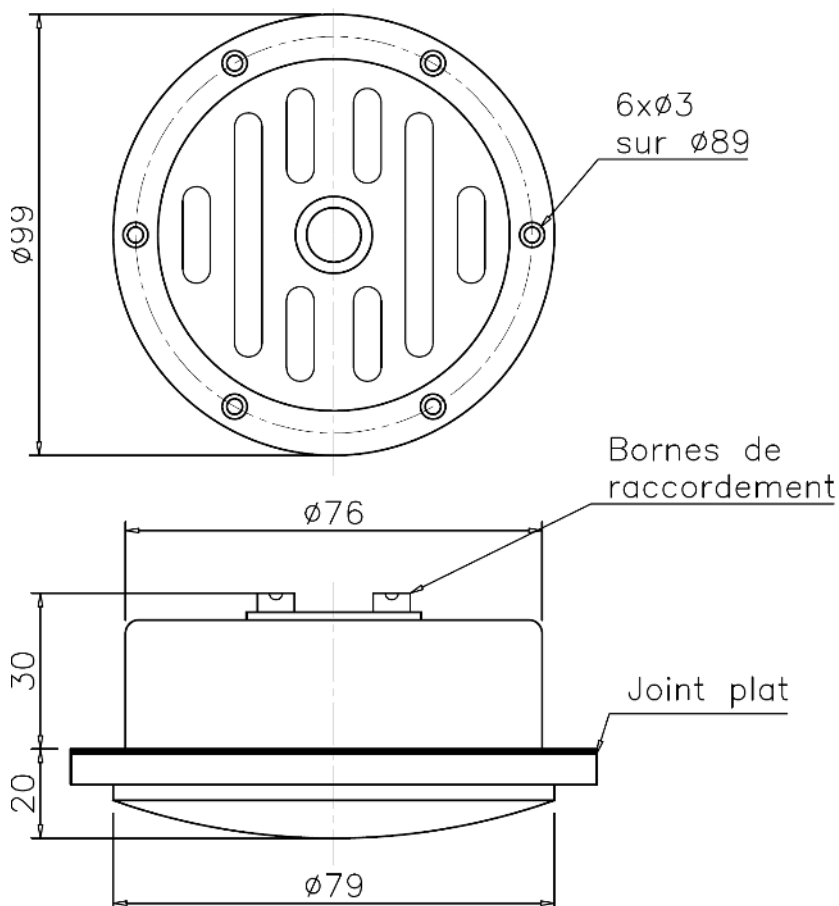

Carcasse métallique électrozinguée  
Consommation courant : 0.28A (50Hz)  
Temps de travail en continu : 3min

	B2	B3	B4
dB à 1m	95-110dBA		
Alimentation	24Vac	48Vac	110Vac

#### Option :

Support plastique pour fixation en saillie  
Hauteur : 58mm



## KLAXON ELECTROMAGNETIQUE

### Modèles 24Vcc

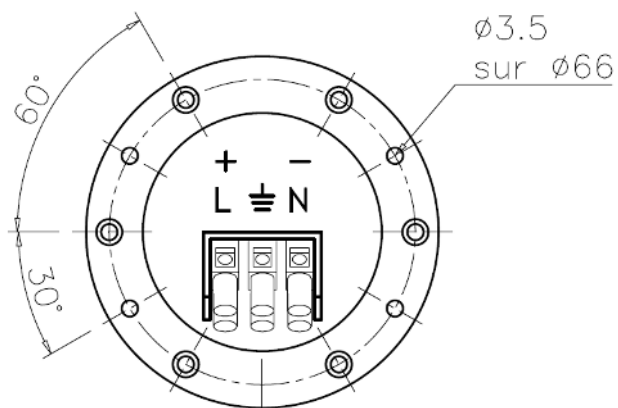
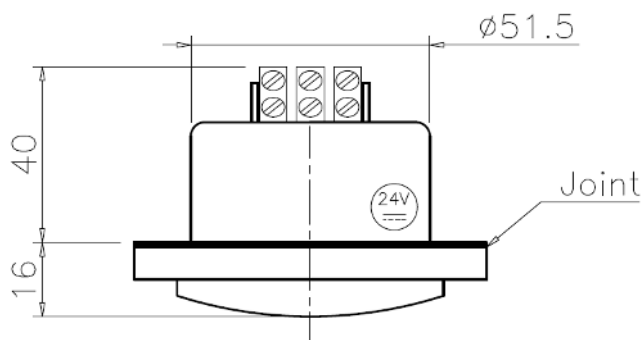
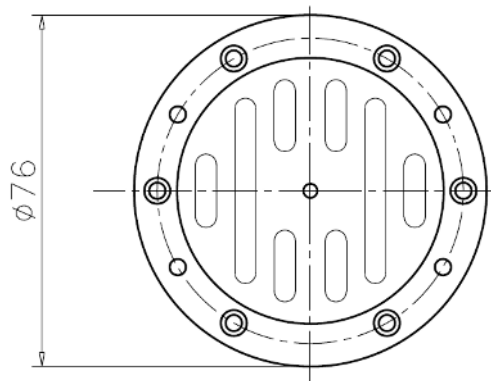

Alimentation : 24Vcc

Db à 1m : 88 dBA

Carcasse métallique électrozinguée

Peinture époxy noire sur façade visible

Consommation courant : 0.40A

Temps de travail en continu : 3min

#### Option :

Support plastique pour fixation en saillie

Hauteur : 56mm



# KLAXON 90/1-H

**36 - 48 V**

**Ø 90 mm**

